

Steca AJ

275-12, 350-24, 400-48, 700-48, 1000-12, 2100-12, 2400-24

The Steca AJ inverter series stands out with its wide range of available power classes and DC input voltages.

This enables the optimal inverter to be used for any application. The cables for connecting the battery and the load are already mounted on the Steca AJ, thus making it easier to install the device. The automatic standby mode considerably reduces the inverter's own consumption. The Steca AJ inverter's excellent overload capacity ensures that even critical loads can be operated easily.



Product features

- True sine wave voltage
- Excellent overload capabilities
- Optimal battery protection
- Automatic load detection
- Best reliability

Electronic protection functions

- Deep discharge protection
- Battery overvoltage shutdown
- Overtemperature and overload protection
- Short circuit protection
- Reverse polarity protection by internal fuse (except Steca AJ 2100-12)
- Acoustic alarm at deep discharge or overheating

Displays

- Multi-coloured LED shows operating states

Operation

- Main switch
- Adjustable load detection

Options

- Types with 115 V / 50 Hz, 115 V / 60 Hz or 230 V / 60 Hz
- Model with protective lacquered mainboard
- Terminal for connection of a remote control (On/Off) for the types Steca AJ 275-12 to Steca AJ 700-48
- Remote control JT8 (On/Off, LED) for connection to Steca AJ 1000-12 to Steca AJ 2400-24

Certificates

- Compliant with European Standards (CE)
- RoHS compliant

275 W...2,400 W

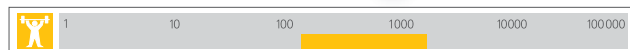

Steca AJ 275-12, AJ 350-24, AJ 400-48

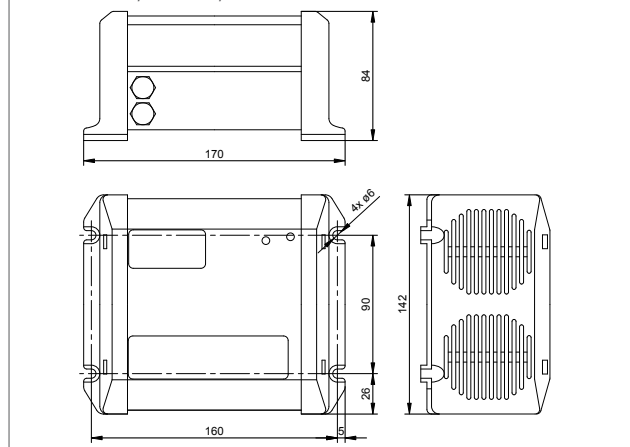

Authorized Distributor



211, Gargash Center, Deira, Dubai, United Arab Emirates
 phone: +971-4-2231185 Fax: +971-4-2271505 URL: www.apexpowerconcepts.com

	275-12	350-24	400-48	700-48	1000-12	2100-12	2400-24
Characterisation of the operating performance							
System voltage	12 V	24 V	48 V	48 V	12 V	12 V	24 V
Continuous power	200 VA	300 VA	300 VA	500 VA	800 VA	2,000 VA	2,000 VA
Power 30 min.	275 VA	350 VA	400 VA	700 VA	1,000 VA	2,100 VA	2,400 VA
Power 5 sec.	450 VA	650 VA	1,000 VA	1,400 VA	2,200 VA	5,000 VA	5,200 VA
Max. efficiency	93 %	94 %	94 %	94 %	93 %	92 %	94 %
Own consumption standby / ON	0.3 W / 2.4 W	0.5 W / 3.5 W	1.1 W / 5.2 W	1.5 W / 12 W	0.7 W / 10 W	0.7 W / 16 W	1.2 W / 16 W
DC input side							
Battery voltage	10.5 V ... 16 V	21 V ... 32 V	42 V ... 64 V	42 V ... 64 V	10.5 V ... 16 V	10.5 V ... 16 V	21 V ... 32 V
AC output side							
Output voltage	230 V AC +0 / -10 % (true sine wave)						
Output frequency	50 Hz +/-0.05 % (crystal controlled)						
Load detection (standby)	2 W			adjustable: 1 W ... 20 W			
Operating conditions							
Ambient temperature	-20 °C ... +50 °C						
Fitting and construction							
Cable length battery / AC	1.2 m / 1 m			1.5 m / 1 m		1.7 m / 1 m	
Degree of protection	IP 30				IP 20		
Dimensions (X x Y x Z)	170 x 142 x 84 mm			252 x 142 x 84 mm	455 x 142 x 84 mm	406 x 273 x 117 mm	
Weight	2.4 kg	2.6 kg		4.5 kg	8.5 kg	19 kg	18 kg

Technical data at 25 °C / 77 °F

